

INSTRUCTIONS FOR THE USE AND CARE OF ZANUSSI FRIDGE FREEZER

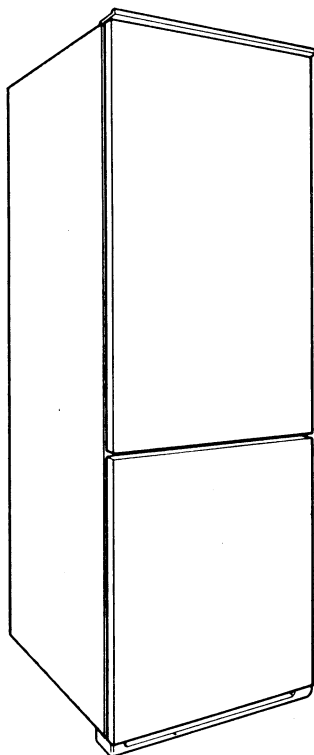

MODEL NO. DI 180/80

ZANUSSI
The appliance of science

It is most important that this instruction book should be retained with the appliance for future reference. Should the appliance be sold or transferred to another owner, or should you move house and leave the appliance, always ensure that the book is supplied with the appliance in order that the new owner can be acquainted with the functioning of the appliance and the relevant warnings.

Refrigeration Warnings

THESE WARNINGS ARE PROVIDED IN THE INTEREST OF SAFETY. YOU MUST READ THEM CAREFULLY BEFORE INSTALLING OR USING THE APPLIANCE.

This appliance is designed to be operated by adults. Children should not be allowed to tamper with the controls or play with the product.

Any electrical work required to install this appliance should be carried out by a qualified electrician or competent person.

This product should be serviced by an authorized Zanussi Network Service Centre, and only genuine Zanussi spare parts should be used.

It is dangerous to alter the specifications or modify this product in any way.

Care must be taken to ensure that the appliance does not stand on the electrical supply cable.

Zanussi domestic refrigerators and fridge/freezers are designed to be used specifically for the storage of edible foodstuffs only.

Frozen food must not be re-frozen once it has been thawed out.

Manufacturers' storage recommendations should be strictly adhered to. Refer to relevant instructions.

There are working parts in this product which heat up. Always ensure that there is adequate ventilation as a failure to do this will result in component failure and possible food loss. See installation instructions.

Parts which heat up should not be exposed. Wherever possible the back of the product should be against a wall.

Before any cleaning or maintenance work is carried out, be sure to switch off the appliance and unplug.

The inner lining of the appliance consists of channels through which the refrigerant passes. If this should be punctured this would damage the appliance beyond repair and cause food loss. DO NOT USE SHARP INSTRUMENTS to scrape off frost or ice. Frost may be removed by using the scraper provided. Under no circumstances should solid ice be forced off the liner. Solid ice should be allowed to thaw when defrosting the appliance. See defrost instructions.

The appliance should be left for 2 hours after installation before it is turned on in order to allow the refrigerant to settle.

Do not place carbonated or fizzy drinks in the freezer as it creates pressure on the container, which may cause it to explode, resulting in damage to the appliance.

This appliance is heavy. Care should be taken when moving it.

Ice lollies can cause frost burns if consumed straight from the freezer.

Under no circumstances should you attempt to repair the appliance yourself. Repairs carried out by inexperienced persons may cause injury or more serious malfunctioning. Refer to your local Zanussi Network Centre, and always insist on genuine Zanussi spare parts.

Contents

Page 6	Getting to know your machine
Page 7	Installation
Page 14	Using your machine
Page 14	The fridge compartment
Page 17	The freezer compartment
Page 20	Looking after your machine
Page 23	Servicing
Page 24	Zanussi guarantee
Page 25	Zanussi 5 year cover

Please note that the specifications of your appliance may differ slightly from those shown in this booklet.

Specifications

DI 180/80

Recess dimensions

Height	1446 mm
Width	560 mm
Depth	550 mm

Furniture door dimensions

Top door	Height	859.5 mm
	Width	600 mm
	Thickness	15-21 mm
Bottom door	Height (min)	607.5 mm
	Width	600 mm
	Thickness	15-21 mm

Capacity gross

Fridge	173 ltrs (6.1 cuft)
Freezer	72 ltrs (2.5 cuft)

Net

Fridge	172 ltrs (6.0 cuft)
Freezer	52 ltrs (1.8 cuft)

Star rating



Power absorbed	110 W
Voltage	220/240 V
Frequency	50 Hz
Average daily units electricity	1.65 KwH

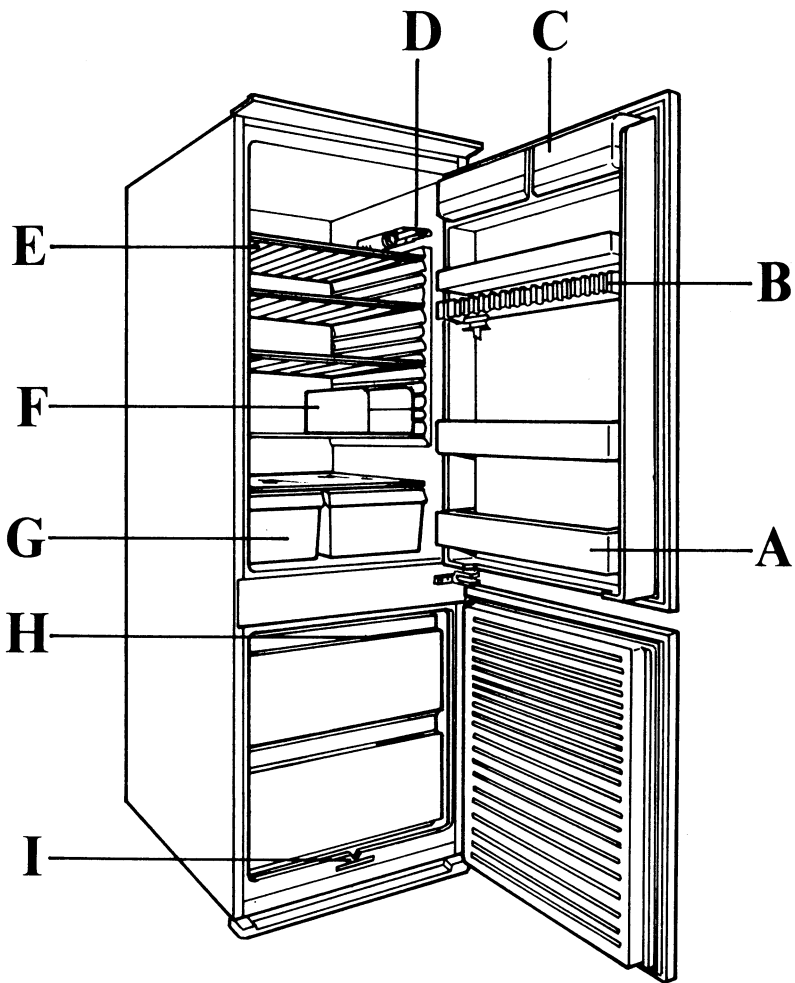

- A. Bottle storage shelf
- B. Drink dispenser
- C. Dairy compartments
- D. Thermostat control
- E. Cantilever bottle shelf

- F. Can dispenser
- G. Salad crispers
- H. Produce storage cards
- I. Defrost spout

Getting to know your machine

A. Bottle storage shelf

For storing tall bottles.

B. Drink dispenser

A container for cooling drinks with an «optic». Removable for easy cleaning and filling, it can be used to store drinks such as water, squash drinks or wine.

C. Dairy compartments

Separate storage compartments for dairy products to prevent tainting.

D. Thermostat control

Allows adjustment of the temperature in the refrigerator to accomodate seasonal changes.

E. Cantilever bottle shelf

Designed for storage of wine; ensures that the cork remains moist whilst the wine is being chilled.

F. Can dispenser

Plastic holder enabling easy dispensing of chilled cans.

G. Salad crispers

Help to keep salad produce fresh.

H. Produce storage cards

Write on, wipe off cards for recording what has been stored in the freezer and when.

I. Defrost spout

To direct defrost water into a suitable container.

Installation

WARNING

IF YOU ARE DISCARDING AN OLD APPLIANCE THAT HAS A LOCK OR CATCH ON THE DOOR, PLEASE ENSURE THAT THIS IS MADE UNUSABLE TO PREVENT YOUNG CHILDREN BEING TRAPPED INSIDE.

Building-in the appliance

The fridge freezer doors have been locked in position for transport by means of pins on both the left and right hand side. Depending upon the position which you choose for your fridge freezer, the door can be hinged on the left or the right.

Right hinging

1

Remove the top and bottom, left hand pins (A+B).

Left hinging

1

Unscrew both top pins (A) and gently remove the fridge door.

2

Remove the plastic cover caps at the left hand, middle hinge position.

3

Remove the middle hinge by unscrewing the two screws, and replace it to the left hand side.

4

Replace the plastic cover caps in the holes left by the middle hinge on the right hand side.

5

Replace the fridge door, and secure it by refitting the pin (A) to the top left hand side of the unit.

6

Remove the bottom, right hand pin (B).

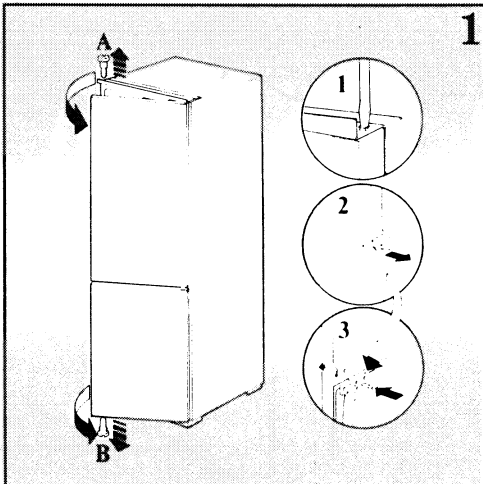

Housing recess: Height	1446 mm
Width (min)	560 mm
Depth	550 mm

See figure 2 for the ventilation requirements of the housing recess.

Push the appliance into the housing unit until the fixing frames (A) figure 3 butt against the kitchen furniture.

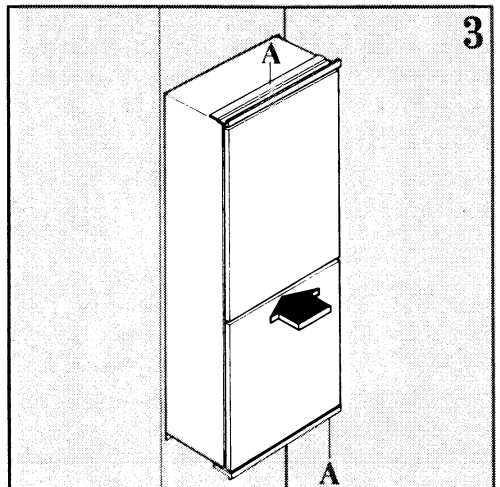
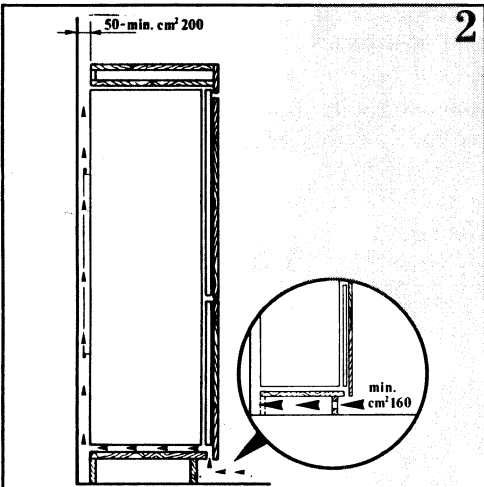

Open the fridge door and push the opposite side to where the door is hinged, against the side of the kitchen furniture (Fig. 4).

Secure the appliance with four screws to the housing unit as shown in Figure 4.

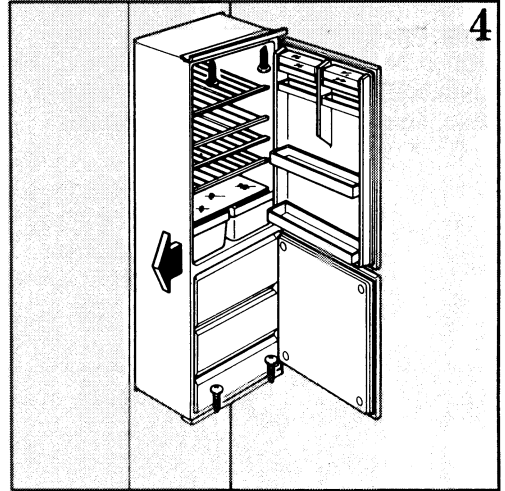

Press the finishing strip into the seam formed between the housing unit and the appliance (Fig. 5), and cover the unused hinge holes with the plastic plugs (B) provided (Fig. 6).

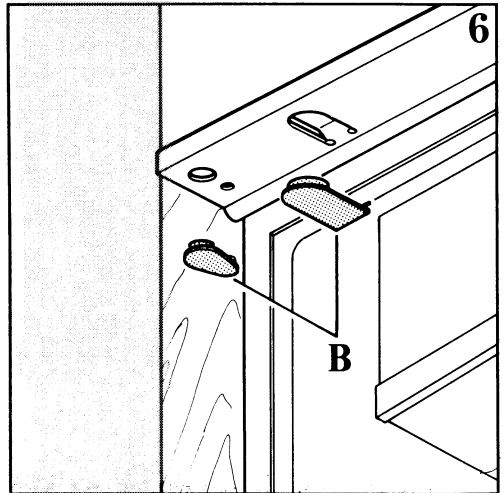
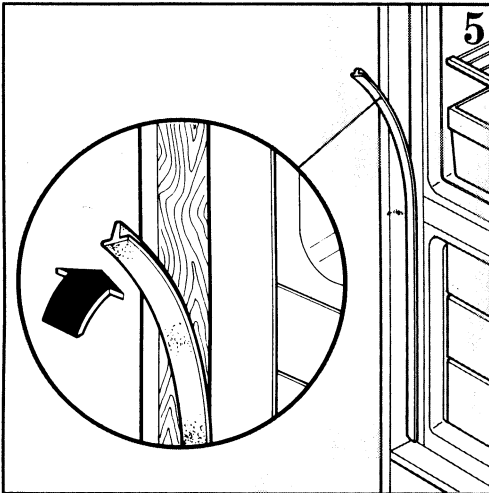

Depending on whether you have chosen left or right hand hinging, drill the appropriate holes in the fridge door and fix the appliance door runners (Fig. 7).

Open the fridge freezer doors to 90° (Fig. 8).

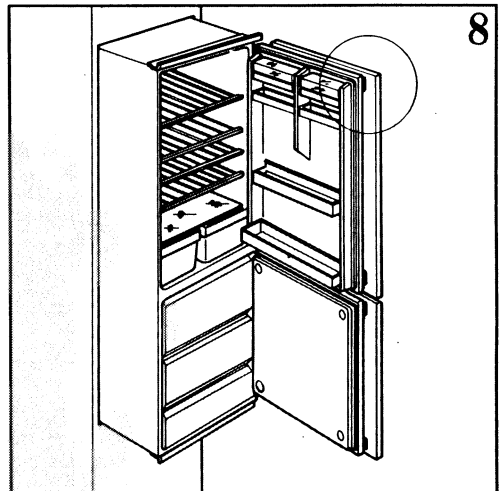
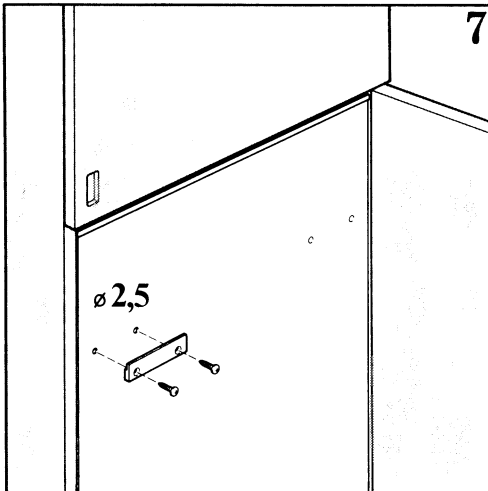

Position the furniture door runners B at the top and bottom of the door as shown in Fig. 9 (lining them up with the appliance door runners A), and secure them loosely. Experiment with the position of the furniture door runners, by sliding to the left or right until the doors run smoothly together. Tighten the furniture door runners and fit the snap-on covers C.

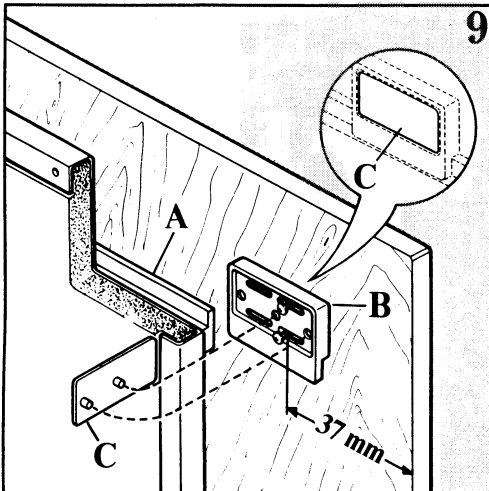

The electrical connections

WARNING

THIS APPLIANCE MUST BE EARTHED.

The manufacturer declines any liability should this safety measure not be observed.

If the plug that is fitted to your appliance is not suitable for your socket outlet, it must be cut off and the appropriate plug fitted.

The cut off plug should be disposed of to prevent the hazard of electric shocks in case it should be plugged into a 13 Amp socket in another part of your home.

IMPORTANT

The wires in the mains lead are coloured in accordance with the following code:

GREEN AND YELLOW - EARTH
BLUE - NEUTRAL
BROWN - LIVE

If you fit your own plug the colours of the wires in the mains lead of your appliance may not correspond with the markings identifying the terminals in your plug, this is what you have to do:
Connect the green and yellow (earth) wire to the terminal in the plug which is marked with the letter «E» or the earth symbol \oplus or coloured green or coloured green and yellow.

Connect the blue (neutral) wire to the terminal in the plug which is marked with the letter «N» or coloured black.

Connect the brown (live) wire to terminal in the plug with the letter «L» or coloured red.

The plug moulded onto the cord incorporates a fuse, for replacement, use a 13 Amp BS1362 fuse. Only ASTA approved fuses should be used.

The fuse cover/carrier colour is the one shown by the coloured insert at the base of the plug.

The plug must not be used if the fuse cover/carrier is lost. A replacement cover/carrier must be obtained from Zanussi Service Agents whose addresses are listed on the attached Zanussi Service Agents Nationwide.

This model has the main terminal board of the type shown in figure. To gain access to the supply cable terminals, remove the lid from the terminal board by releasing the two catches «A» and «B» with the aid of a small screwdriver.

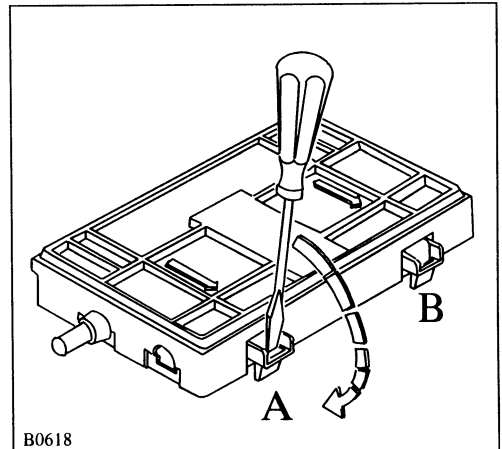

This appliance complies with E.E.C. directive number 87/308 of 2.6.87 relative to radio interference suppression.

To start the cooling system, insert the plug into the wall socket and switch on.

Using your machine

Before using

Remove all securing tapes. Wash the inside of the appliance with lukewarm water and a little bicarbonate of soda (one teaspoonful to 1.2 litres/ 2 pints of water). Do not use soap or detergent as the smell might linger. Dry thoroughly.

The fridge

Open the fridge door and turn the thermostat knob beyond the «0» (off position). Temperature adjustment is obtained by turning the thermostat knob to the required setting. A medium setting of 3 or 4 is generally most suitable. However, the internal temperature will be affected by the location, room temperature, the amount of food being stored and the number of times which the door is opened.

Turn the knob clockwise to higher numbers to obtain a lower temperature, and anticlockwise if a less cold temperature is required.

The required temperature inside the fridge compartment is from 0°C to 7°C (32°F to 45°F).

To obtain the best results from the refrigerator, neither hot food nor liquids, which may evaporate, should be placed in the refrigerator.

Cover all foods, particularly those with a strong aroma.

Do not pack the fridge too tightly or cover shelves with paper or card, so as not to obstruct the free circulation of air.

Place meat to be stored in an airtight box.

Cooked foods should be well covered. Fruit and vegetables should be thoroughly cleaned and placed in the salad drawers.

Butter and cheese should be placed in special airtight containers or wrapped in foil or polythene bags to exclude as much air as possible.

Milk bottles should have a cap and should be stored in the bottle rack on the door.

Food should be positioned inside the refrigerator compartment as indicated in figure 10.

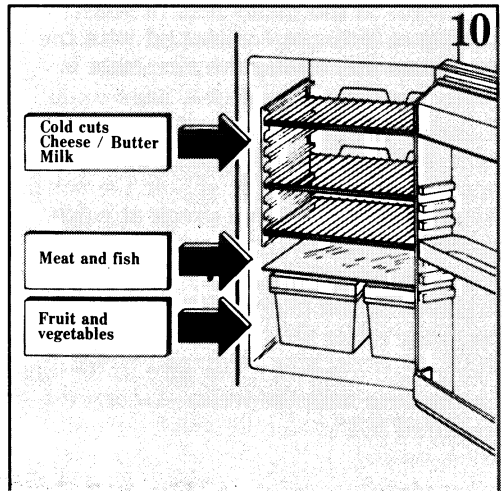

Suggested maximum storage times

Type of food	Storage time
Uncooked fresh meat	
Poultry, beef, and lamb	1 - 2 days
Pork	1 - 2 days
Sausages	3 days
Mince and offal	1 - 2 days
Cooked meat	
Ham, sliced meat	2 - 3 days
Pies	1 day
Casseroles and pate	2 days
Poultry	2 - 3 days
Bacon	1 week
Dairy produce	
Milk	2 - 3 days
Cream	1 week
Butter	3 - 4 weeks
Hard cheese	3 - 4 weeks
Soft cheese	1 week
Vegetables and salads	1 week
Fruit	2 weeks

Storage times will vary according to the type of food and how fresh it is when put into the fridge compartment but no food should be stored for longer than the times stated.

Drinks dispenser (Fig. 11)

The container for cooling drinks is located in the door of the fridge. It is easily removed from its runners for filling and cleaning by pulling sharply outwards. Remove the clip on lid to fill.

To pour a drink, press a glass upwards against the tap arms. To stop the flow of liquid remove the glass.

Between using the dispenser, we recommend that you rinse it several times with hot water. For a thorough cleaning of the container add a spoonful of bicarbonate of soda to the rinsing water. Push the dispenser tap on and off several times to allow sugar deposits from soft drinks or wines to dissolve, or alternatively remove for cleaning by unscrewing in an anticlockwise direction. Empty the container and rinse thoroughly with clean water.

If using the dispenser to store fresh fruit juice, particular attention should be paid to the manufacturers storage instructions. It is also advisable to clean the dispenser thoroughly between every filling, using a solution of sterilising fluid.

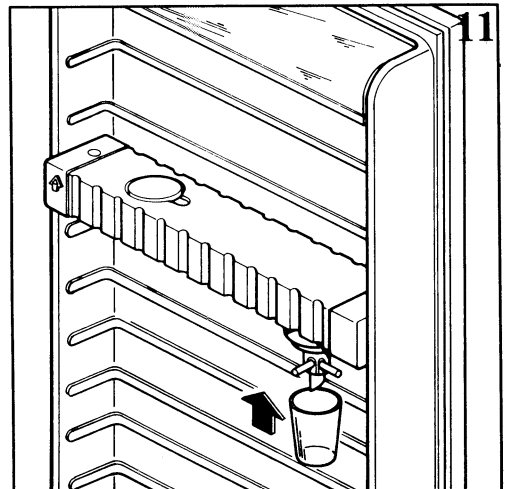

The freezer compartment

The four star freezer compartment is suitable for storage of commercially frozen food marked with the symbol ***❄❄❄**. The temperature reached of -18°C is suitable for long term storage of frozen foods; this means up to three months, unless otherwise stated by the manufacturer. It is also suitable for freezing fresh foods.

Do not exceed the storage times shown by the manufacturer on the commercially frozen food packets.

Temperature control

The temperature within the freezer is controlled by the same thermostat which controls the temperature within the fridge.

Normally, it is not necessary to adjust the thermostat setting when freezing fresh food. However, if you wish to fast freeze food then the thermostat control should be turned to the highest number, about one hour before you want to freeze your food.

REMEMBER THOUGH, THAT THE FRIDGE COMPARTMENT TEMPERATURE COULD DROP BELOW 0°C .

Frozen food storage

Your freezer compartment has the following capacity:

Net storage volume: 52 litres

WE ADVISE YOU TO RUN YOUR FREEZER FOR TWO HOURS BEFORE STORING FROZEN FOOD.

Freezing fresh food

In any 24 hours you can freeze up to 3 kg (6.6lb).

Place the food to be frozen in the top compartment of the freezer as this is the coldest part.

Only freeze top quality, fresh and thoroughly cleaned foodstuffs.

Remember also that lean foods keep better and longer than fatty foods.

Salt too reduces storage times. Wrap the foods in a foil or food film, or freezer bags, ensuring that the wrapping is well sealed. In this way, by avoiding contact with the air, the retention of colour, flavour and nutritional value is greater.

Mark the packs, or the storage cards with contents and dates so that you can keep a check on storage periods. Do not allow fresh food to touch food which is already frozen.

During the freezing process, ensure that the freezer door remains closed.

Once the food is completely frozen, (which will take up to 24 hours depending on the amount) return the thermostat control to setting 3 or 4.

Attention

Do not put carbonated liquids, (fizzy drinks etc.), in the freezer compartment.

Water ices, if consumed immediately after removal from the freezer, can possibly result in a low temperature skin burn condition.

If there is a power failure during the storage of frozen food, do not open the door during the whole time of the failure. If the freezer is fully loaded the frozen food will not be affected if the power cut is of short duration; otherwise it is recommended to consume the food within a very short time.

Ice making

Fill the ice tray with water to the top of each ice cube compartment, and place it in the freezer compartment. To release the ice cubes, twist the tray along its length.

Thawing

Deep frozen or frozen foods, prior to being used, can be thawed in the fridge or at room temperature depending on the time available. Small food items may even be cooked from frozen; in this case cooking will take longer.

Any frozen food which is allowed to thaw accidentally should either be eaten as soon as possible or thrown away.

Alternatively, if the food is uncooked and has not been completely defrosted it can be cooked and refrozen.

DEFROSTED, COOKED FOOD MUST NEVER BE REFROZEN.

Important points to remember...

DO...

- Cover or wrap liquids and foods, particularly those with strong odours.
- Put vegetables and salads in the salad drawer, in plastic bags.
- Cover melons and pineapples and only store for short periods.
- Rotate stocks of frozen foods; date markings will help with this.
- Leave the door ajar when the fridge freezer is not in use.

DO NOT...

- Obstruct the air circulation in the fridge by tightly packing stored items.
- Let food or containers touch the refrigerator cooling plate.
- Store bananas in the fridge.
- Use a sharp instrument to hasten defrosting or remove ice trays.

Looking after your machine

Defrosting

The fridge compartment is automatically defrosted.

Frost is eliminated from the back wall of the fridge compartment every time the motor compressor stops.

The defrost water drains out through a trough into a special container on the back of the appliance where it evaporates (see Fig. 12).

The defrost water drain hole should be cleaned at regular intervals. To do this, use the special cleaner provided, which you will find already inserted into the discharge hole (Fig. 13).

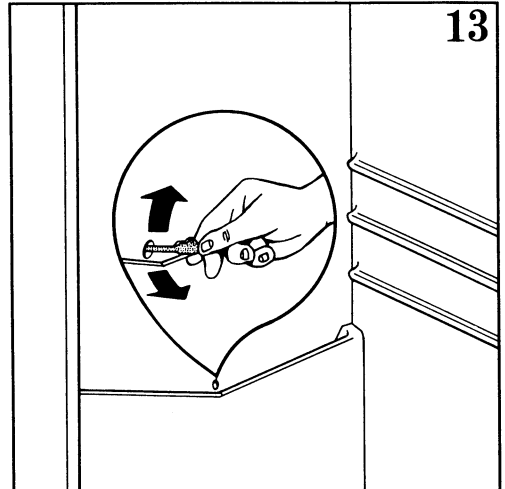
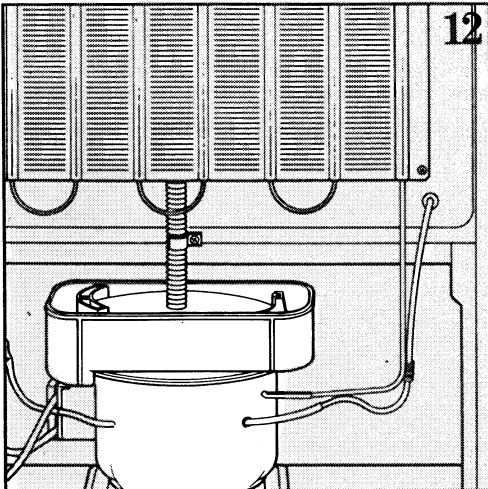

The freezer compartment will become progressively covered with frost. This frost acts as an insulator and thus prevents the cold from reaching the food, this should be removed whenever the frost exceeds 5 mm (1/4 inch).

NEVER USE A SHARP METAL TOOL TO SCRAPE OFF THE FROST FROM THE INTERIOR AS YOU COULD DAMAGE IT.

The frost should be removed with the special scraper provided.

To carry out complete defrosting proceed as follows:

Remove any stored food from the compartment and wrap well in several layers of newspaper, and put in a cool place.

Switch off and remove the plug from the wall socket, or turn the thermostat to the «0» setting.

Leave the freezer door open.

Introduce the plastic scraper into the seating at the bottom of the freezer beneath the defrost spout, and place a bowl underneath it to collect the defrost water (Fig. 14).

When defrosting is completed, dry the freezer thoroughly. Remove the plastic scraper and replace it in its storage position in the basket (Fig. 15).

Replace the plug in the socket, or set the thermostat at setting 3 or 4. After letting the appliance run for at least 2 hours, replace the previously removed food.

Important

A temperature rise of the frozen food packs during defrosting may shorten their storage life.

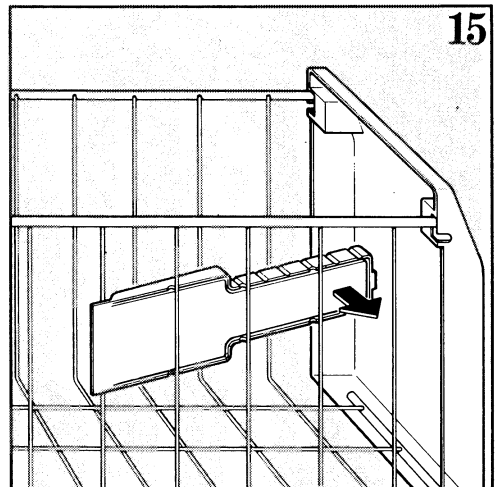
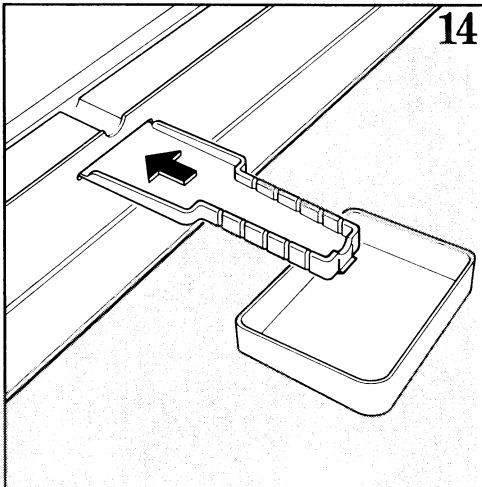

Cleaning

The most suitable time to clean your fridge freezer would be after defrosting before turning the appliance back on again.

Clean out the interior with a clean cloth wrung out in a solution of warm water and bicarbonate of soda (1 teaspoon to 600 ml / 1 pint of water).

NEVER USE DETERGENTS, OR ABRASIVE POWDERS, HIGHLY PERFUMED CLEANING MATERIALS OR WAX POLISHES TO CLEAN THE INTERIOR OF THE FRIDGE AS THESE WILL DAMAGE THE SURFACES AND LEAVE A STRONG SMELL.

During periods when the appliance is not in use, take the following precautions:

Unplug the freezer from the power supply.

Remove all food stuffs from the freezer.

Clean the interior and all accessories; leaving the interior of the cabinet open to prevent unpleasant odours lingering in the appliance.

Servicing

If, having followed these instructions carefully, your machine fails to work properly, contact your local Zanussi Service Network, whose details can be found by looking under «Z» in your local telephone directory. Before you do that though it is worth making a few simple checks yourself.

Is the plug firmly connected to the wall socket and the socket switched on? Check the power supply by plugging in another appliance.

Check that there is not a power failure. Switch on the house lights.

Is the fuse in the plug intact and are the wires in the mains lead correctly connected to the plug? (see page 13 for Electrical connections).

Have you turned the thermostat to the correct setting?

Has the door been left open causing the temperature to rise?

If there are water drops on the bottom of the fridge compartment, check that the defrost water channel is clear.

IN-GUARANTEE CUSTOMERS SHOULD ENSURE THAT THE ABOVE CHECKS HAVE BEEN MADE AS THE ENGINEER WILL MAKE A CHARGE IF THE FAULT IS NOT A MECHANICAL OR ELECTRICAL BREAKDOWN.

*** Please note that proof of purchase is required for any in-guarantee service calls.**

Replacing the interior light bulb

Prior to undertaking this operation, be sure to unplug the appliance from the wall socket as a safety precaution.

If the interior light does not come on when the door is opened, you will need to gain access to the interior light bulb. To do this, remove the bulb housing cover by unscrewing the screw and by sliding it out. Check that the bulb is correctly screwed into its socket. If it is burnt out, replace with a similar 10W bulb. Replace the cover by sliding it back in. Fasten it by means of the previously removed screw.

Peace of mind for twelve months

ZANUSSI STANDARD GUARANTEE CONDITIONS

This guarantee is in addition to your statutory and other legal rights which will not be excluded or in any way diminished by the return of this guarantee card.

We, Zanussi Ltd., undertake that if, within twelve months of the date of the purchase, this ZANUSSI appliance or any part thereof is proved to be defective by reason only of faulty workmanship or materials, we will, at our option, repair or replace the same **FREE OF ANY CHARGE** for labour, materials or carriage on condition that:

- The appliance has been correctly installed and used only on the electricity supply stated on the rating plate.
- The appliance has been used for normal domestic purposes only, and in accordance with the manufacturer's operating and maintenance instructions.
- The appliance has not been serviced, maintained, repaired, taken apart or tampered with by any person not authorised by us.
- The appliance is still in the possession of the original purchaser.

All service work under this guarantee must be undertaken by a Zanussi Service Force Centre.

Any appliance or defective part replaced shall become our property.

Exclusions

This guarantee does not cover:

- Damage or calls resulting from transportation, improper use or neglect, the replacement of any light bulbs or removable parts of glass or plastic.
- Costs incurred for calls to put right machines improperly installed or calls to machines outside the United Kingdom.
- Appliances found to be in use within a commercial environment, plus those which are the subject of rental agreements.
- Products of Zanussi manufacture which are **NOT** marketed by Zanussi Ltd.
- EEC Countries - the standard guarantee is applicable but is subject to the owner's responsibility and cost to ensure the appliance meets the standards set by the country to which the product is taken. The Zanussi company in the country concerned will be pleased to advise further. Sight of your purchase receipt will be required by them.

or five years

ZANUSSI 5 YEAR COVER CONDITIONS

For a once-only payment you can extend your Standard Guarantee to 5 years. All the conditions and exclusions of the Standard Guarantee apply.

Notes

1. Products supplied as «seconds», refurbished, damaged or shop-soiled are not eligible for Zanussi 5 Year Cover.
2. The issue of a cover does NOT by virtue of our having done so, nullify the exclusions.

3. The Engineer will need to check the details of your Cover card and may make a charge for his services if it is not presented to him at the time of his call.

4. The date of purchase, or the date of initial payment (deposit) of the appliance will be deemed the date of commencement of cover.

5. Covers issued are not refundable or transferable.

Guarantee Record

Appliance purchased from _____ on _____
Guarantee card no _____ Model no _____
Serial no _____ (These details may be
Your name _____ taken from your
Address _____ Guarantee Record Card)

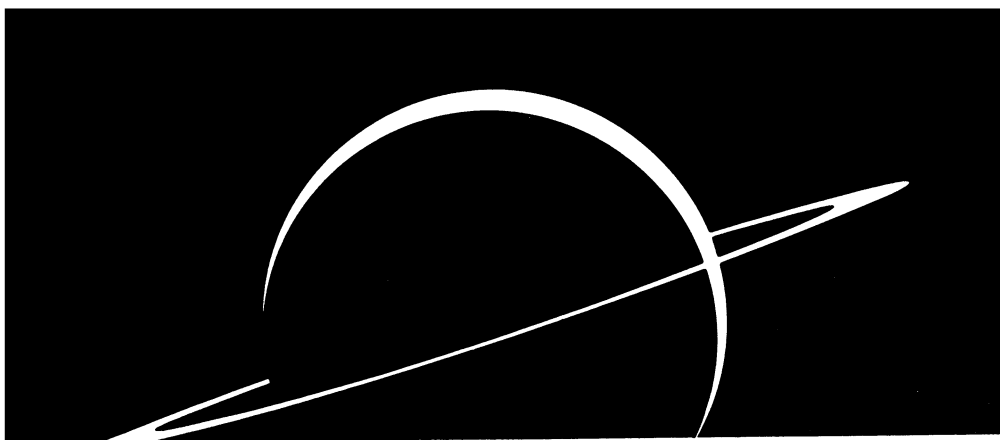

ZANUSSI

The appliance of science

Zanussi Ltd., Zanussi House, Newbury

The information in this manual is correct at time of going to press.
Zanussi reserve the right to alter specifications without notice.